

Grinding Process Feed Solutions

**Proven reliable solutions
for feeding parts from random bulk supply to
Centerless and Horizontal grinding process.**

**Ask about our multipass systems with run segmentation
and lights out multi-pass automation with part inspection systems.**

Gentle, Non-Marking
Polypropylene Brushlon
EZ-Clean, Non-Abrasive

Cantilevered Discharge Conveyor w/ precision
top hold down, precision x and z bracket, drip pan
and optional swale cut out

**Industry Standard
Controls**

Zero Drop Part Supply
Fist in first out, minimal
Re-Circulation

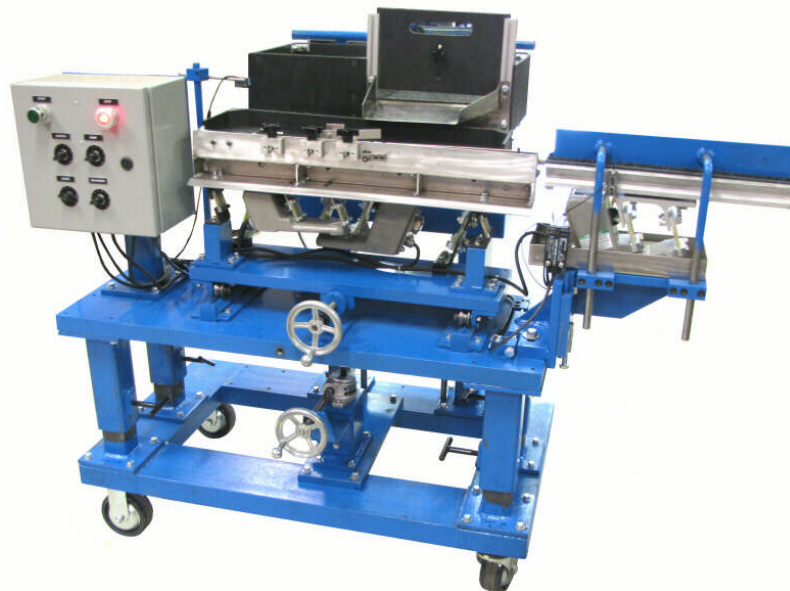

ular Platform Scaled
our project requirements

*Model Shown: Centerless Grinder Feeder-Portable Model 1436
w/Space Saver Supply Hopper & Standard Base with X & Z Adjustment*

Both standard quick interchange tooling allows for a wide range of parts to run in a single feeder at rates to 240"/min (610 cm/min). Quick Change Tube Tooling allows for Square, near square & under square parts at feed rates of greater than 120 inches/min (305 cm/min). Vision guided active tooling available.

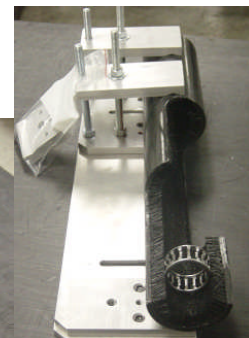
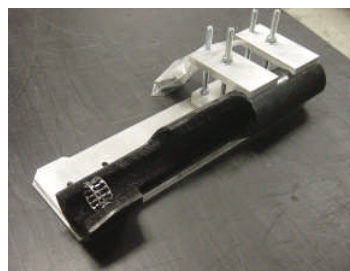
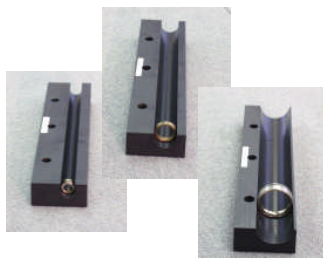

Dyna-Slide

□ CDS LIPE Div. * www.cds-lipe.com * 800-448-7822

Horizontal Vibratory Feeder Features :

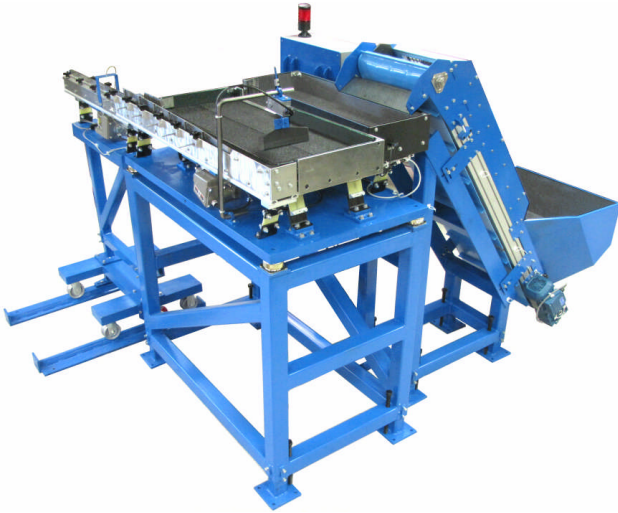

- Modular, flexible design that is superior for applications that requires gentle handling such as polished surfaces.
- Easily integrated to all grind systems
- Compact modular platform handles a family of parts in a single feeder.
- May be integrated with any type of bulk part supply system
- Z, Y and X Adjustable Machine Base
- Square or Near Square Parts
- Simple to retool when part changes warrant.
- Removable polypropylene brush makes it EZ clean system.
- Stainless steel, tool steel or UHMW wear surfaces
- Wrench less interchangeable or adjustable tooling allows for wide range of parts to be handled within single feeder . Quick change tooling is available.

- Quiet operation- > 60 dba -Typical
- Gentle handling on wide variety of parts
- Portable base for ease of integration.
- Price competitive w/ vibratory bowls.
- Operating speeds <120" to 240" /Min.
- 305 to 609.6 cm/min
- Simple changeovers for wide range of parts allows single feeder to run wide range of part sizes in one w/ simple, quick tooling changes.
- Endures wet, harsh environments
- Can be integrated w/ bulk handling equipment discharge conveyors, gauging, inspection and controls to create a complete automated multipass cell.
- Vision guided loading, sortation & orientation tooling available
- Feeder can be easily reconfigured for new parts or changes in part geometry.
- Simple cleaning and replacement of wear surfaces
- Available as both std. models and customized to meet your application requirements.

Standard Models	Dimensions	Part Range
F00929	9" x 29"	> 2"
F01436	14" X 36"	> 4.50"
F02148	21" X 48"	> 6"
F03054	30" X 54"	> 8"
F03660	36" X 60"	> 10"

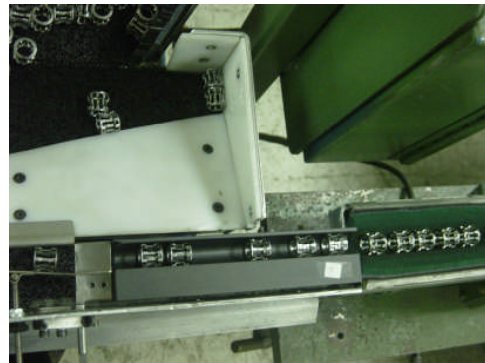

304 SS Drip Pan & Top Hold Down

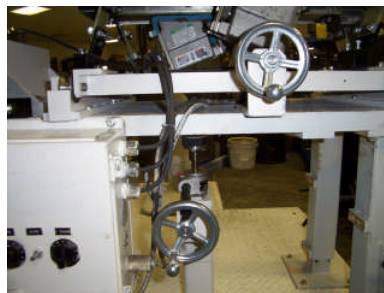

Z-Elevation Adjustor

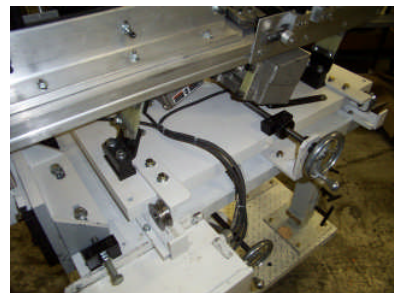

X-Adjustor

Features developed with decades of experience feeding grinding systems of all types and makes.

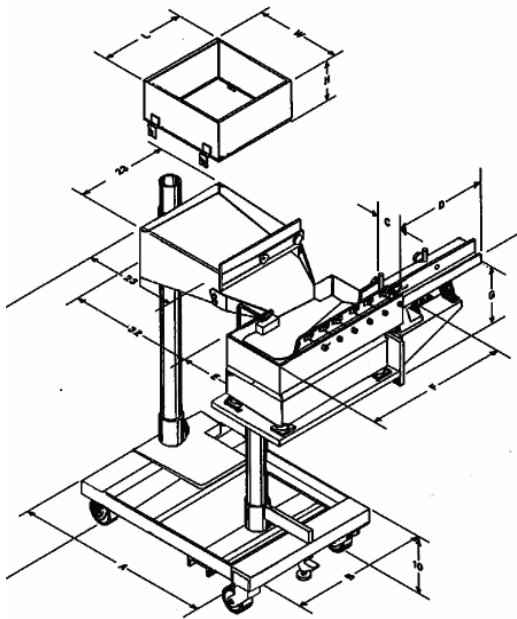

Orienter/Feeder Dimensions

Specifications	Model Numbers				
	F0820	F0929	F1436	F2148	
A	29	50	50	64	
B	20	35	35	47	
C	2	2	5	5	
D	18	18	24	24	
E	8	9	14	27	
F	20	29	36	48	
G	8	12	15	15	
X	35-45	36-55	36-55	36-55	
Part Size Guide					
Part Dia. or Width	Min.	0.13	0.25	0.38	0.38
	Max.	0.5	1	2.5	4.5
Part Length	Min.	0.13	25	0.5	0.5
	Max.	1	3	6	9

Capacity expander	Specifications		
	W	H	L
3'	21	21	9
5'	38	38	11
10'	38	38	17
15'	38	38	23

Pedestal Mounted Feeder w/ Supply Hopper



Feeder w/ Horizontal Supply Hopper X, Z adjustor, Back Pressure Control & Drip Pan w/ Well Return Angle



Transport & Accumulation Conveyors to operator side of grinder w/ drip pans



Feeder w/ tray unloader



Post Grind "Gentle" Accumulation Tables



Part orientation to rolling attitude for supply to side grinder

□ CDS LIPE Div. * www.cds-lipe.com * 800-448-7822

DynaSlide

Feed Systems configured to meet your needs...not the other way around.



Hi Level Intelligent Tote Dunper, 5 cu ft pedestal hopper
F1463 Feeder w/ custom tooling



Simple Feeder- V0336 w/ x,
x & z adjustment features

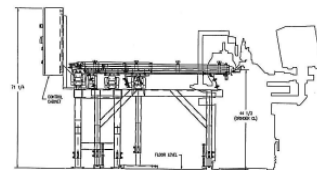
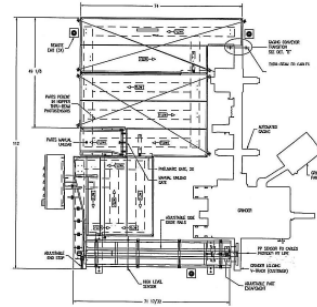

Gentle supply and non-contact by-pass

Lights Our Automation -Integrated with Automated Load
System and automated gauge system.

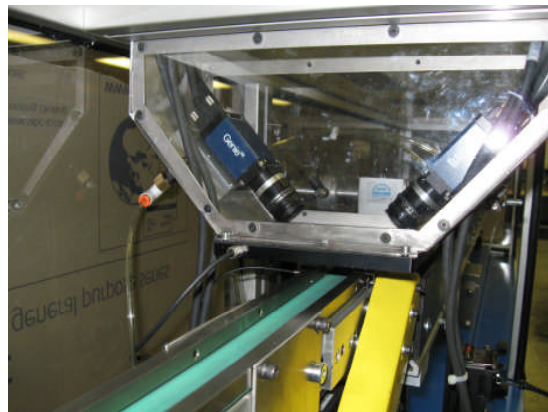

Vision Guided
Sortation-Defined End Leading
Orientation
Part Loading



Rob,Bar,Tube,Pipe –Magazine Type Feeders



Rod & Shaft Feeders from random bulk supply

□ CDS LIPE Div. * www.cds-lipe.com * 800-448-7822